

**Comment**

9-10-18 copied from 18s

Creator:	John Ledbetter	DFD Lineshop	Project:	Sta 39 Exterior Speakers	Customer:	Denver Fire Dept.
Checked:	9-10-18		Installation:		Diagram No.:	
Date:	1/16/14 8:58 AM/6/10/22 9:27 AM		File:	Sta 39 Ext spkrs 9-10-18.lsc	Page:	1 / 4

# Station 39 Exterior Speakers ( NIGHT shut "OFF" ) 9-10-18

# NOT USED AT THIS TIME

This clock turns exterior speakers on / off. So the speakers are off at night.

**Q1-contacts  
for exterior  
speakers**

**Q2-contacts  
for exterior  
speakers**

## MESSAGE SECTION

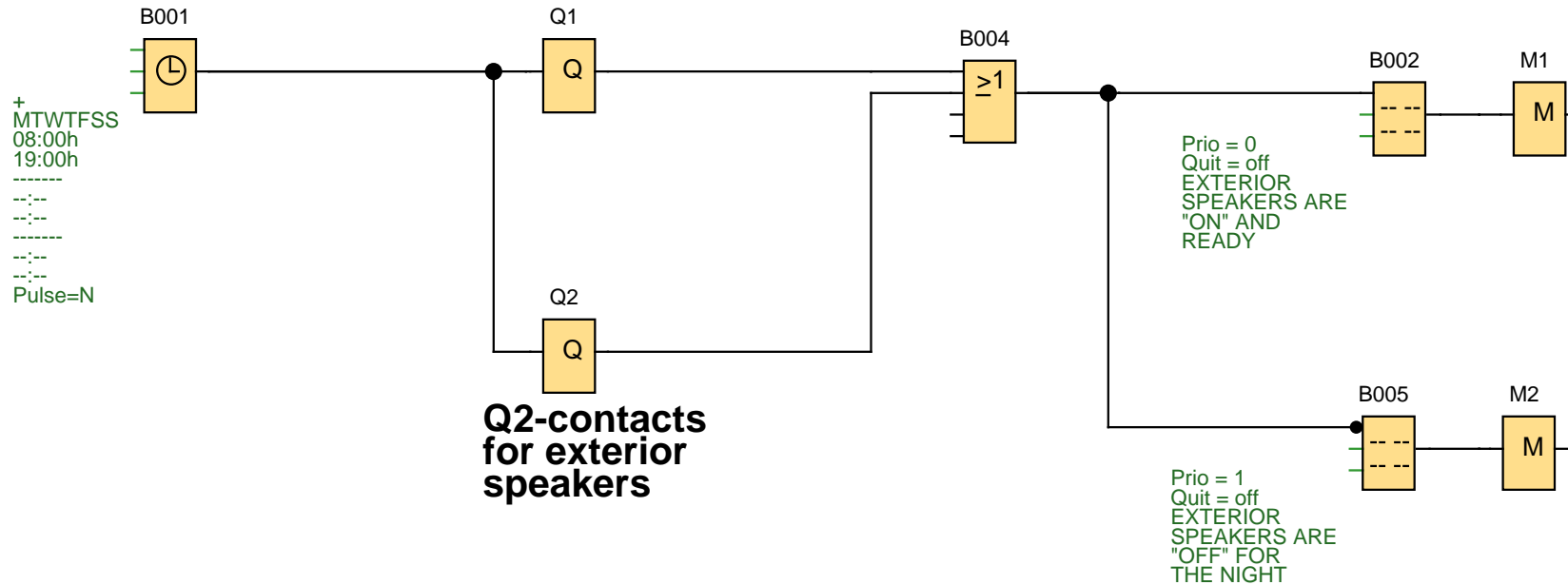

Creator:	John Ledbetter	DFD Lineshop	Project:	Sta 39 Exterior Speakers	Customer:	Denver Fire Dept.
Checked:	9-10-18		Installation:		Diagram No.:	
Date:	1/16/14 8:58 AM/6/10/22 9:27 AM		File:	Sta 39 Ext spkrs 9-10-18.lsc	Page:	2 / 4

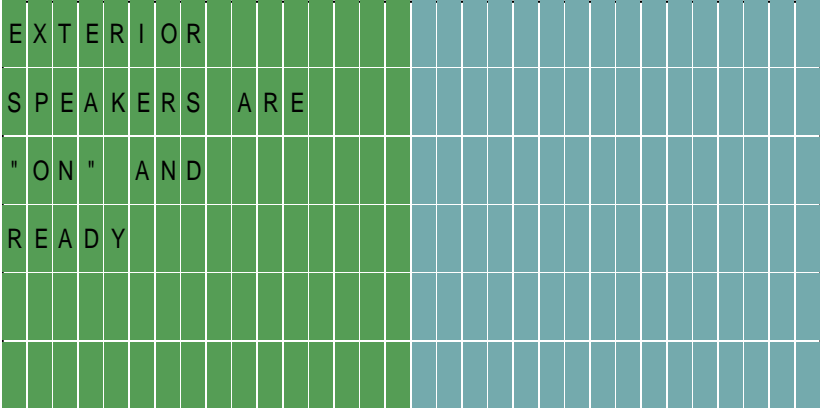
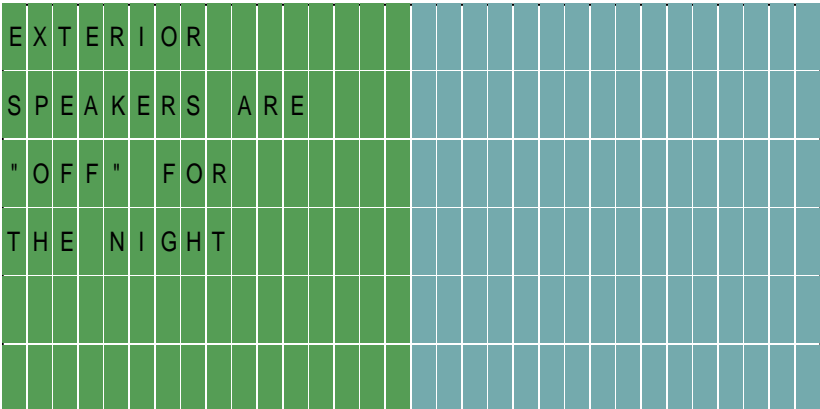
Block Number (Type)	Parameter					
B001(Seven-day time switch) :	<pre> + MTWTFSS 08:00h 19:00h ----- -:- -:- ----- -:- -:- Pulse=N           </pre>					
B002(Message texts) :  	<pre> Prio = 0 Quit = off Text1: enabled Text2: disabled Ticker setting - CBC - Line1: N - Line2: N - Line3: N - Line4: N - Line5: N - Line6: N Message Destination - Both           </pre>					
B005(Message texts) :  	<pre> Prio = 1 Quit = off Text1: enabled Text2: disabled Ticker setting - CBC - Line1: N - Line2: N - Line3: N - Line4: N - Line5: N - Line6: N Message Destination - Both           </pre>					
Q1(Output) : Q1-contacts for exterior speakers						
Q2(Output) : Q2-contacts for exterior speakers						
Creator:	John Ledbetter	DFD Lineshop	Project:	Sta 39 Exterior Speakers	Customer:	Denver Fire Dept.
Checked:	9-10-18		Installation:		Diagram No.:	
Date:	1/16/14 8:58 AM/6/10/22 9:27 AM		File:	Sta 39 Ext spkrs 9-10-18.isc	Page:	3 / 4

Connection	Label
M1	
M2	
Q1	
Q2	

Creator:	John Ledbetter	DFD Lineshop	Project:	Sta 39 Exterior Speakers	Customer:	Denver Fire Dept.
Checked:	9-10-18		Installation:		Diagram No.:	
Date:	1/16/14 8:58 AM/6/10/22 9:27 AM		File:	Sta 39 Ext spkrs 9-10-18.lsc	Page:	4 / 4